

LECTURE NOTES
ON
MANUFACTURING PROCESSES

B. Tech III semester (R18)



Prepared By

G. Aravind Reddy
Assistant Professor

V. Mahidhar Reddy
Assistant Professor

DEPARTMENT OF MECHANICAL ENGINEERING
INSTITUTE OF AERONAUTICAL ENGINEERING
(Autonomous)
Dundigal, Hyderabad - 500 043

MANUFACTURING PROCESSES

III Semester: ME								
Course Code	Category	Hours / Week			Credits	Maximum Marks		
		L	T	P		C	CIA	SEE
AMEB05	Core	3	0	0	3	30	70	100
		Contact Classes: 45		Tutorial Classes: Nil		Practical Classes: Nil		Total Classes: 45
COURSE OBJECTIVES:								
The course should enable the students to:								
I. Understand and develop an appreciation of the manufacturing processes in correlation with material properties.								
II. Learn the material properties which change the shape, size and form of the raw materials into the desirable product.								
III. Understand the processes for creating products by conventional or unconventional manufacturing								
MODULE-I	CASTING						Classes: 09	
Casting: Steps involved in making a casting, its applications, patterns and types of patterns, pattern allowances and their construction, types of casting processes, solidification of casting.								
MODULE-II	WELDING						Classes: 09	
Welding: Welding types, Oxy-fuel gas welding, cutting, standard time and cost calculations, arc welding Process, forge welding, resistance welding, thermit welding. Inert gas welding, TIG welding, MIG welding, friction welding, induction pressure welding, explosive welding, electron beam welding, laser welding, soldering and brazing. Heat affected zone in welding, welding defects, causes and remedies, destructive and non-destructive testing of welds.								
MODULE-III	METAL FORMING						Classes: 09	
Forming: Hot working, cold working, strain hardening, recovery, re-crystallization and grain growth, comparison of properties of cold and hot worked parts, rolling fundamentals, theory of rolling, types of rolling mills and products;								
Forces in rolling and power requirements, stamping, forming and other cold working processes: Blanking and piercing, bending and forming, drawing and its types, wire drawing and tube drawing; coining; hot and cold spinning, types of presses and press tools, forces and power requirements for the above operations.								
MODULE-IV	EXTRUSION AND RAPID PROTOTYPING						Classes: 09	
Extrusion of Metals: Basic extrusion process and its characteristics, hot extrusion and cold extrusion, forward extrusion and backward extrusion, impact extrusion, extruding equipment, tube extrusion and Pipe making, hydrostatic extrusion, forces in extrusion; Additive manufacturing: Rapid prototyping and rapid tooling.								

MODULE-V	FORGING	Classes: 09
<p>Forging processes: Forging operations and principles, tools, forging methods, Smith forging, drop forging, roll forging, forging hammers: Rotary forging, forging defects, cold forging, swaging, forces in forging operations.</p>		
Text Books:		
1.Kalpakjian and Schmid, Manufacturing processes for engineering materials -Pearson India, 5 th Edition 2014.		
Reference Books:		
<ol style="list-style-type: none"> 1. Mikell P. Groover, Fundamentals of Modern Manufacturing: Materials, Processes, and Systems John Wiley & Sons Inc., 4th Edition, 2008. 2. Degarmo, Black & Kohser, Materials and Processes in Manufacturing (9th Edition) John Wiley & Sons Inc., 7th Edition, 2012. 		
Web References:		
1. https://books.google.co.in/books/about/Manufacturing_Processes_Reference_Guide.html?id=6x1smAf_PAcC		
E-Text Books:		
1. https://books.google.co.in/books?id=6wFuw6wufTMC&printsec=frontcover#v=onepage&q&f=false		

MODULE-I

CASTING

Metal Casting Process

Manufacturing

- Manufacturing in its broadest sense is the process of converting raw materials into useful products.
- It includes
 - i) Design of the product
 - ii) Selection of raw materials and
 - iii) The sequence of processes through which the product will be manufactured.

Casting

Casting is the process of producing metal parts by pouring molten metal into the mould cavity of the required shape and allowing the metal to solidify. The solidified metal piece is called as “casting”.

Types of casting

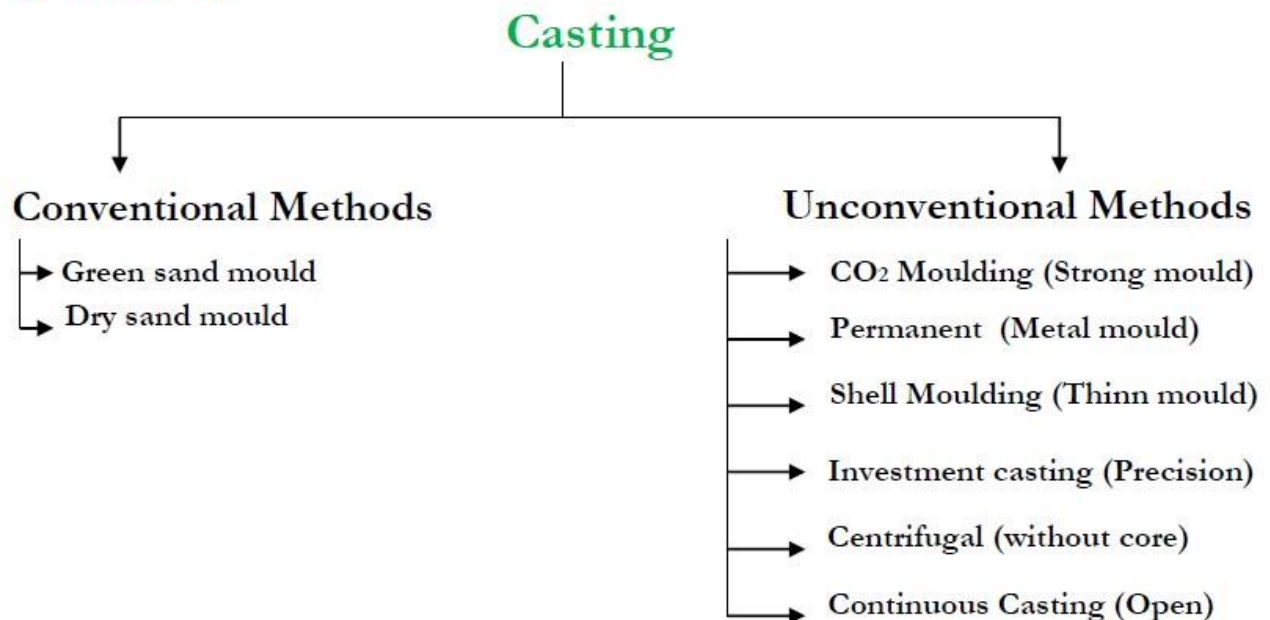

Advantages

- Design flexibility
- Reduced costs
- Dimensional accuracy
- Versatility in production

Disadvantages

- Lot of molten metal is wasted in riser & gating
- Casting may require machining to remove rough surfaces

Sand Casting is simply melting the metal and pouring it into a preformed cavity, called mold, allowing (the metal to solidify and then breaking up the mold to remove casting. In sand casting expandable molds are used. So for each casting operation you have to form a new mold.

- Most widely used casting process.
- Parts ranging in size from small to very large
- Production quantities from one to millions
- Sand mold is used.
- Patterns and Cores
 - Solid, Split, Match-plate and Cope-and-drag Patterns
 - Cores – achieve the internal surface of the part

Molds

- Sand with a mixture of water and bonding clay
- Typical mix: 90% sand, 3% water, and 7% clay
- to enhance strength and/or permeability

Sand – Refractory for high temperature

Size and shape of sand

Small grain size -> better surface finish

Large grain size -> to allow escape of gases during pouring

Irregular grain shapes -> strengthen molds due to interlocking but to reduce permeability

Types of sand

- a) Green-sand molds - mixture of sand, clay, and water; "Green" means mold contains moisture at time of pouring.
- b) Dry-sand mold - organic binders rather than clay and mold is baked to improve strength
- c) Skin-dried mold - drying mold cavity surface of a green-sand
 - mold to a depth of 10 to 25 mm, using torches or heating

Steps in Sand Casting

The cavity in the sand mold is formed by packing sand around a pattern, separating the mold into two halves

- The mold must also contain gating and riser system
 - For internal cavity, a core must be included in mold
 - A new sand mold must be made for each part
1. Pour molten metal into sand mold
 2. Allow metal to solidify
 3. Break up the mold to remove casting
 4. Clean and inspect casting
 5. Heat treatment of casting is sometimes required to improve metallurgical properties

Testing of Mould & Core sand

- 1) Preparation of standard test specimen
- 2) Mould hardness test
- 3) Core hardness test
- 4) Moisture content test on foundry sand
- 5) Sieve analysis
- 6) Clay content test
- 7) Permeability test
- 8) Compression, shear test

Other Expendable Mold Casting

- Shell Molding
- Vacuum Molding
- Expanded Polystyrene Process
- Investment casting
- Plaster and Ceramic Mold casting

Steps in shell-molding

Shell-mold casting yields better surface quality and tolerances. The process is described as follows:

The 2-piece pattern is made of metal (e.g. aluminum or steel), it is heated to between 175°C- 370°C, and coated with a lubricant, e.g. silicone spray.

Each heated half-pattern is covered with a mixture of sand and a thermoset resin/epoxy binder.

The binder glues a layer of sand to the pattern, forming a shell. The process may be repeated to get a thicker shell.

The assembly is baked to cure it.

The patterns are removed, and the two half-shells joined together to form the mold; metal is poured into the mold.

When the metal solidifies, the shell is broken to get the part.

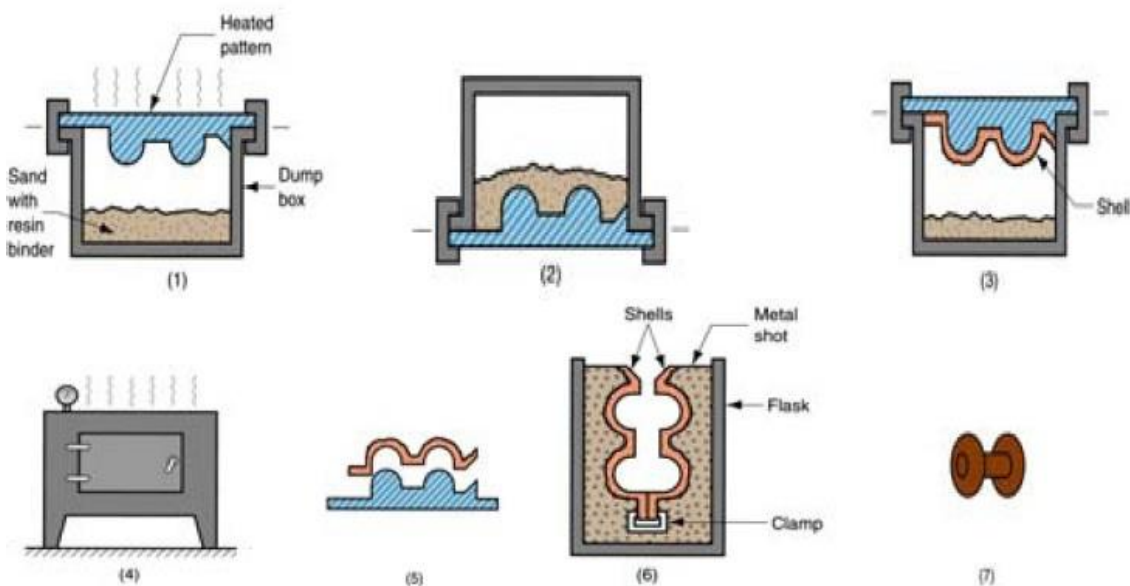

Advantages

- Smoother cavity surface permits easier flow of molten metal and better surface finish on casting
- Good dimensional accuracy
- Machining often not required
- Mold collapsibility usually avoids cracks in casting
- Can be mechanized for mass production

Disadvantages

- More expensive metal pattern
- Difficult to justify for small quantities

Investment Casting

- Investment casting produces very high surface quality and dimensional accuracy.
- Investment casting is commonly used for precision equipment such as surgical equipment, for complex geometries and for precious metals.
- This process is commonly used by artisans to produce highly detailed artwork.
- The first step is to produce a pattern or replica of the finished mould. Wax is most commonly used to form the pattern, although plastic is also used.
- Patterns are typically mass-produced by injecting liquid or semi-liquid wax into a permanent die.
- Prototypes, small production runs and specialty projects can also be undertaken by carving wax models.
- Cores are typically unnecessary but can be used for complex internal structures. Rapid prototyping techniques have been developed to produce expendable patterns.
- Several replicas are often attached to a gating system constructed of the same material to form a tree assembly. In this way multiple castings can be produced in a single pouring.

Casting with expendable mould: Investment Casting

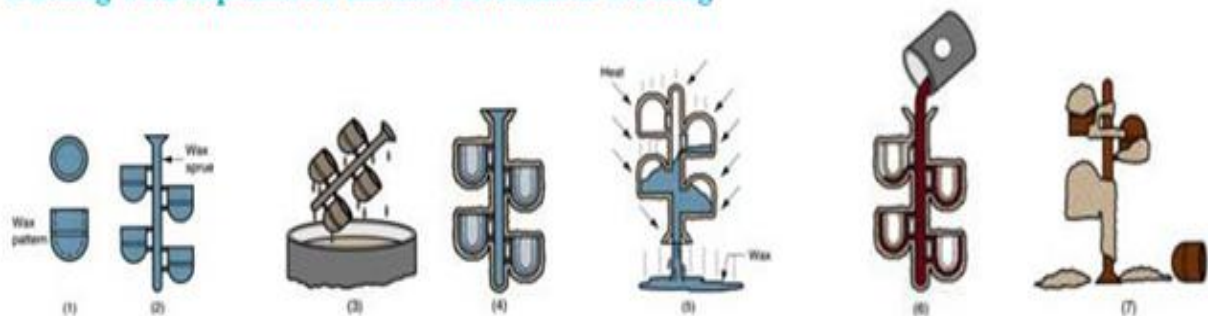

Advantages

- Parts of great complexity and intricacy can be cast
- Close dimensional control and good surface finish
- Wax can usually be recovered for reuse
- Additional machining is not normally required - this is a net shape process

Disadvantages

- Many processing steps are required
- Relatively expensive process

Plaster Molding

- Similar to sand casting except mold is made of plaster of Paris (gypsum - $\text{CaSO}_4 \cdot 2\text{H}_2\text{O}$)
- Plaster and water mixture is poured over plastic or metal pattern to make a mold

Advantages

- Good dimensional accuracy and surface finish
- Capability to make thin cross-sections in casting

Disadvantages

- Moisture in plaster mold causes problems:
- Mold must be baked to remove moisture
- Mold strength is lost when is over-baked, yet moisture content can cause defects in product
- Plaster molds cannot stand high temperatures

Permanent Mold Casting

Basic Permanent Mold Process

- Uses a metal mold constructed of two sections designed for easy, precise opening and closing
- Molds for lower melting point alloys: steel or cast iron and Molds for steel: refractory material, due to the very high pouring temperatures

Permanent Mold Casting Process

- The two halves of the mold are made of metal, usually cast iron, steel, or refractory alloys. The cavity, including the runners and gating system are machined into the mold halves.
- For hollow parts, either permanent cores (made of metal) or sand-bonded ones may be used, depending on whether the core can be extracted from the part without damage after casting.
- The surface of the mold is coated with clay or other hard refractory material – this improves the life of the mold. Before molding, the surface is covered with a spray of graphite or silica, which acts as a lubricant. This has two purposes – it improves the flow of the liquid metal, and it allows the cast part to be withdrawn from the mold more easily.
- The process can be automated, and therefore yields high throughput rates.
- It produces very good tolerance and surface finish.
- It is commonly used for producing pistons used in car engines; gear blanks, cylinder heads, and other parts made of low melting point metals, e.g. copper, bronze, aluminum, magnesium, etc.

Advantage

- Good surface finish and dimensional control and Fine grain due to rapid solidification.

Disadvantage

- Simple geometric part, expensive mold.

Example

It is commonly used for producing pistons used in car engines; gear blanks, cylinder heads, and other parts made of low melting point metals, e.g. copper, bronze, aluminum, magnesium, etc.

Basic Permanent Mold Process

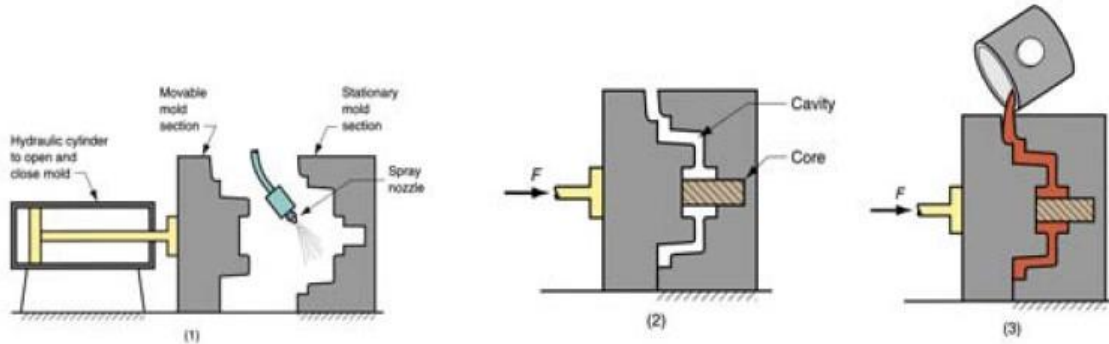

Advantages

- Good dimensional control and surface finish
- More rapid solidification caused by the cold metal mold results in a finer grain structure, so stronger castings are produced

Limitations

- Generally limited to metals of lower melting point
- Simple part geometries compared to sand casting because of the need to open the mold
- High cost of mold
- Due to high mold cost, process is best suited to automated high volume production

Testing of Mould & Core sand

- 1) Preparation of standard test specimen
- 2) Mould hardness test
- 3) Core hardness test
- 4) Moisture content test on foundry sand
- 5) Sieve analysis
- 6) Clay content test
- 7) Permeability test
- 8) Compression, shear test

Die Casting

- Die casting is a very commonly used type of permanent mold casting process.
 - It is used for producing many components of home appliances (e.g rice cookers, stoves, fans, washing and drying machines, fridges), motors, toys and hand-tools
 - The molten metal is injected into mold cavity (die) under high pressure (7-350MPa). Pressure maintained during solidification.
 - Hot Chamber (Pressure of 7 to 35MPa)
 - The injection system is submerged under the molten metals (low melting point metals such as lead, zinc, tin and magnesium)
 - Cold Chamber (Pressure of 14 to 140MPa)
 - External melting container (in addition aluminum, brass and magnesium)
- Molds are made of tool steel, mold steel, maraging steel, tungsten and molybdenum.
- Single or multiple cavity
 - Lubricants and Ejector pins to free the parts

- Venting holes and passageways in die
- Formation of flash that needs to be trimmed

Properties of die-casting

- 1) Huge numbers of small, light castings can be produced with great accuracy.
- 2) Little surface finishing is required.
- 3) Permanent mold (dies can be used over and over)

Advantages

– High production, Economical, close tolerance, good surface finish, thin sections, rapid cooling

Hot-Chamber Die Casting

In a hot chamber process (used for Zinc alloys, magnesium) the pressure chamber connected to the die cavity is filled permanently in the molten metal.

The basic cycle of operation is as follows:

- (i) die is closed and gooseneck cylinder is filled with molten metal;
- (ii) plunger pushes molten metal through gooseneck passage and nozzle and into the die cavity; metal is held under pressure until it solidifies;
- (iii) die opens and cores, if any, are retracted; casting stays in ejector die; plunger returns, pulling molten metal back through nozzle and gooseneck;
- (iv) ejector pins push casting out of ejector die. As plunger uncovers inlet hole, molten metal refills gooseneck cylinder.

The hot chamber process is used for metals that (a) have low melting points and (b) do not alloy with the die material, steel; common examples are tin, zinc, and lead.

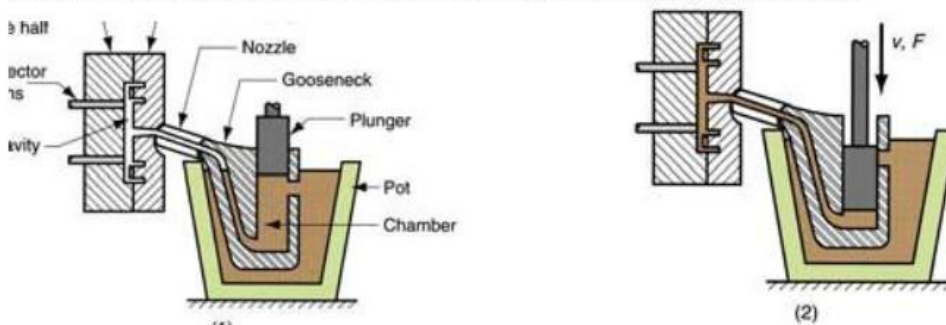

Cold Chamber Die Casting

In a cold chamber process, the molten metal is poured into the cold chamber in each cycle. The operating cycle is

- (i) Die is closed and molten metal is ladled into the cold chamber cylinder;
- (ii) plunger pushes molten metal into die cavity; the metal is held under high pressure until it solidifies;
- (iii) die opens and plunger follows to push the solidified slug from the cylinder, if there are cores, they are retracted away;
- (iv) ejector pins push casting off ejector die and plunger returns to original position

This process is particularly useful for high melting point metals such as Aluminum, and Copper (and its alloys).

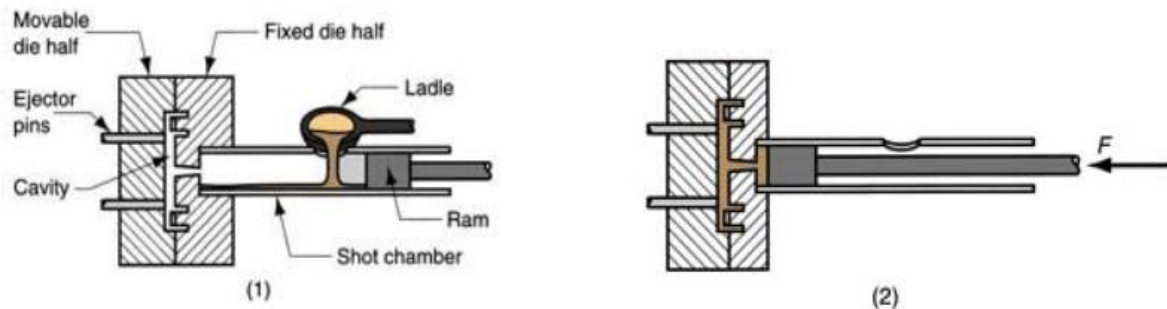

Advantages

- Economical for large production quantities
- Good dimensional accuracy and surface finish
- Thin sections are possible
- Rapid cooling provides small grain size and good strength to casting

Disadvantages

- Generally limited to metals with low metal points
- Part geometry must allow removal from die cavity

Centrifugal casting

Centrifugal casting uses a permanent mold that is rotated about its axis at a speed between 300 to 3000 rpm as the molten metal is poured.

Centrifugal forces cause the metal to be pushed out towards the mold walls, where it solidifies after cooling.

Centrifugal casting has greater reliability than static castings. They are relatively free from gas and shrinkage porosity.

Surface treatments such as case carburizing, flame hardening and have to be used when wear resistant surface must be combined with a hard tough exterior surface.

One such application is bimetallic pipe consisting of two separate concentric layers of different alloys/metals bonded together.

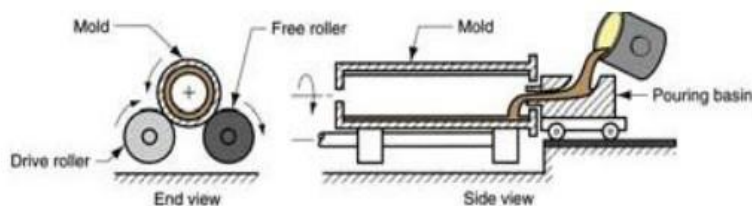

Carbon Dioxide Moulding

- This sand is mixed with 3 to 5 % sodium silicate liquid base binder in a muller for 3 to 4 minutes. Additives such as coal powder, wood flour, sea coal, dextrin may be added to improve its properties.
- Aluminium oxide, Kaolin clay may also be added to the sand.

- Patterns used in this method may be coated with Zinc of 0.05 mm to 0.13 mm and then spraying a layer of aluminium or brass of about 0.25 mm thickness for good surface finish and good results.

Advantages

- Operation is speedy since we can use the mould and cores immediately after processing.
- Heavy and rush orders
- Floor space requirement is less
- Semi skilled labour may be used.

Disadvantages

Difficult in reusing the moulding sand.

Process	Advantages	Disadvantages	Examples
Sand	Wide range of metals, sizes, shapes, low cost	poor finish, wide tolerance	engine blocks, cylinder heads
Shell mold	better accuracy, finish, higher production rate	limited part size	connecting rods, gear housings
Expendable pattern	Wide range of metals, sizes, shapes	patterns have low strength	cylinder heads, brake components
Plaster mold	complex shapes, good surface finish	non-ferrous metals, low production rate	prototypes of mechanical parts
Ceramic mold	complex shapes, high accuracy, good finish	small sizes	impellers, injection mold tooling
Investment	complex shapes, excellent finish	small parts, expensive	jewellery
Permanent mold	good finish, low porosity, high production rate	Costly mold, simpler shapes only	gears, gear housings
Die	Excellent dimensional accuracy, high production rate	costly dies, small parts, non-ferrous metals	precision gears, camera bodies, car wheels
Centrifugal	Large cylindrical parts, good quality	Expensive, limited shapes	pipes, boilers, flywheels

Furnaces

Cupola Furnace

- A continuous flow of iron emerges from the bottom of the furnace.
- Depending on the size of the furnace, the flow rate can be as high as 100 tonnes per hour.

At the metal melts it is refined to some extent, which removes contaminants. This makes this process more suitable than electric furnaces for dirty charges.

Induction Furnace:

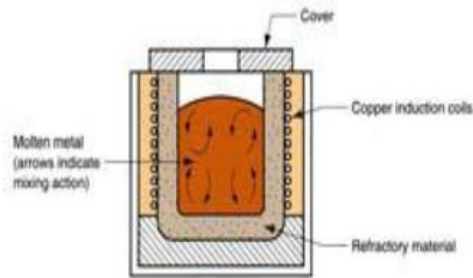

Casting defects

Defects may occur due to one or more of the following reasons:

- Fault in design of casting pattern
- Fault in design on mold and core
- Fault in design of gating system and riser
- Improper choice of moulding sand
- Improper metal composition
- Inadequate melting temperature and rate of pouring

Some common defects in castings:

a) Misruns b) Cold Shut c) Cold Shot d) Shrinkage Cavity e) Microporosity f) Hot Tearing
Misruns:

a) Misruns

It is a casting that has solidified before completely filling the mold cavity.

Typical causes include

- 1) Fluidity of the molten metal is insufficient,
- 2) Pouring Temperature is too low,
- 3) Pouring is done too slowly and/or
- 4) Cross section of the mold cavity is too thin.

b) Cold Shut

A cold shut occurs when two portion of the metal flow together, but there is lack of fusion between them due to premature freezing. Its causes are similar to those of a Misruns.

c) Cold Shots

When splattering occurs during pouring, solid globules of the metal are formed that become entrapped in the casting. Poring procedures and gating system designs that avoid splattering can prevent these defects.

d) Shrinkage Cavity

This defects is a depression in the surface or an internal void in the casting caused by solidification shrinkage that restricts the amount of the molten metal available in the last region to freeze.

e) Microporosity

This refers to a network of a small voids distributed throughout the casting caused by localized solidification shrinkage of the final molten metal in the dendritic structure.

f) Hot Tearing

This defect, also called hot cracking, occurs when the casting is restrained or early stages of cooling after solidification.

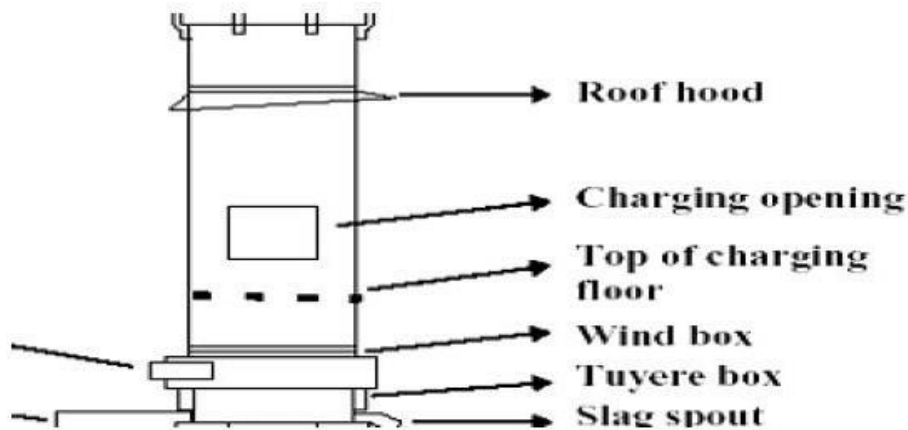

Direct Fuel-fired furnace

- Crucible Furnace
- Electric-arc Furnace
- Induction Furnace
- Pouring with ladle
- Solidification – watch for oxidation
- Trimming, surface cleaning, repair and heat treat, inspection

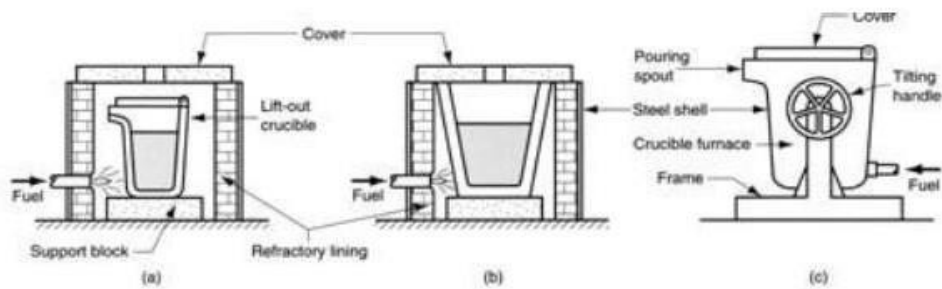

Three types: (a) lift-out crucible, (b) stationary pot, from which molten metal must be ladle (c) tilting-pot furnace

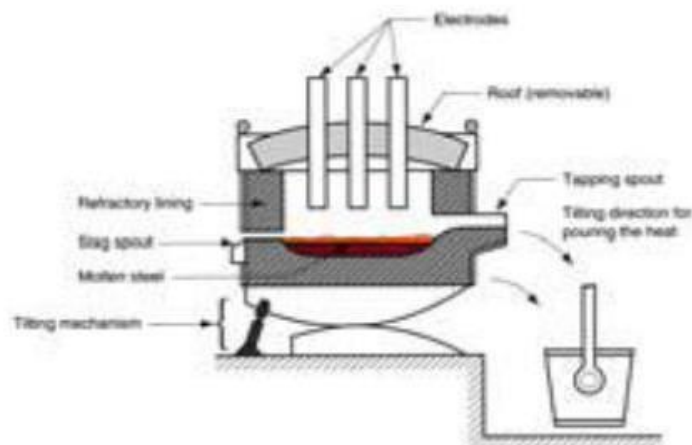

Induction Furnace:

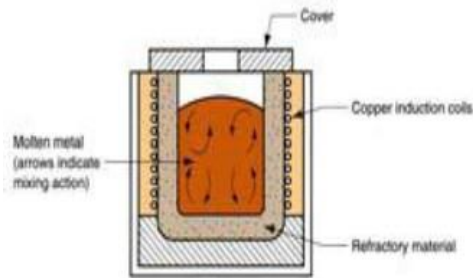

Casting defects

Defects may occur due to one or more of the following reasons:

- Fault in design of casting pattern
- Fault in design on mold and core
- Fault in design of gating system and riser
- Improper choice of moulding sand
- Improper metal composition
- Inadequate melting temperature and rate of pouring

Some common defects in castings:

a) Misruns b) Cold Shut c) Cold Shot d) Shrinkage Cavity e) Microporosity f) Hot Tearing
Misruns:

a) Misruns

It is a casting that has solidified before completely filling the mold cavity.

Typical causes include

- 1) Fluidity of the molten metal is insufficient,
- 2) Pouring Temperature is too low,
- 3) Pouring is done too slowly and/or
- 4) Cross section of the mold cavity is too thin.

b) Cold Shut

A cold shut occurs when two portion of the metal flow together, but there is lack of fusion between them due to premature freezing. Its causes are similar to those of a Misruns.

c) Cold Shots

When splattering occurs during pouring, solid globules of the metal are formed that become entrapped in the casting. Poring procedures and gating system designs that avoid splattering can prevent these defects.

d) Shrinkage Cavity

This defects is a depression in the surface or an internal void in the casting caused by solidification shrinkage that restricts the amount of the molten metal available in the last region to freeze.

e) Microporosity

This refers to a network of a small voids distributed throughout the casting caused by localized solidification shrinkage of the final molten metal in the dendritic structure.

f) Hot Tearing

This defect, also called hot cracking, occurs when the casting is restrained or early stages of cooling after solidification.

MODULE-II WELDING

Welding

Welding is a materials joining process which produces coalescence of materials by heating them to suitable temperatures with or without the application of pressure or by the application of pressure alone, and with or without the use of filler material.

Welding is used for making permanent joints.

It is used in the manufacture of automobile bodies, aircraft frames, railway wagons, machine frames, structural works, tanks, furniture, boilers, general repair work and ship building.

Classification of welding processes

(i) Arc welding

- Carbon arc
- Metal arc
- Metal inert gas
- Tungsten inert gas
- Plasma arc
- Submerged arc
- Electro-slag

(ii) Gas Welding

- Oxy-acetylene
- Air-acetylene
- Oxy-hydrogen

iii) Resistance Welding

- Butt
- Spot
- Seam
- Projection
- Percussion

(iv) Thermit Welding

(v) Solid State Welding

Friction
Ultrasonic
Diffusion
Explosive

(vi) Newer Welding

Electron-beam
Laser

(vii) Related Process

Oxy-acetylene cutting
Arc cutting
Hard facing
Brazing
Soldering

Welding practice & equipment

STEPS :

- Prepare the edges to be joined and maintain the proper position
- Open the acetylene valve and ignite the gas at tip of the torch
- Hold the torch at about 45deg to the work piece plane
- Inner flame near the work piece and filler rod at about 30 – 40 deg
- Touch filler rod at the joint and control the movement according to the flow of the material

Two Basic Types of AW Electrodes

- Consumable – consumed during welding process
 - Source of filler metal in arc welding
- Nonconsumable – not consumed during welding process
 - Filler metal must be added separately

Consumable Electrodes

Forms of consumable electrodes

- Welding rods (a.k.a. sticks) are 9 to 18 inches and 3/8 inch or less in diameter and must be changed frequently
- Weld wire can be continuously fed from spools with long lengths of wire, avoiding frequent interruptions

In both rod and wire forms, electrode is consumed by arc and added to weld joint as filler metal.

Nonconsumable Electrodes

- Made of tungsten which resists melting
- Gradually depleted during welding (vaporization is principal mechanism)
- Any filler metal must be supplied by a separate wire fed into weld pool

Flux

A substance that prevents formation of oxides and other contaminants in welding, or dissolves them and facilitates removal

- Provides protective atmosphere for welding
- Stabilizes arc
- Reduces spattering

Arc welding

Uses an electric arc to coalesce metals

Arc welding is the most common method of welding metals

Electricity travels from electrode to base metal to ground

Arc welding Equipments

- A welding generator (D.C.) or Transformer (A.C.)
- Two cables- one for work and one for electrode
- Electrode holder
- Electrode
- Protective shield
- Gloves
- Wire brush
- Chipping hammer
- Goggles

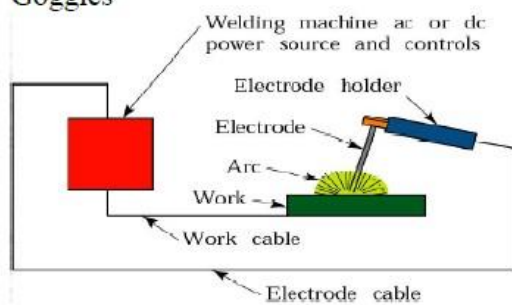

Advantages

- Most efficient way to join metals
- Lowest-cost joining method
- Affords lighter weight through better utilization of materials
- Joins all commercial metals
- Provides design flexibility

Disadvantages

- Manually applied, therefore high labor cost.
- Need high energy causing danger
- Not convenient for disassembly.
- Defects are hard to detect at joints.

GAS WELDING

- Sound weld is obtained by selecting proper size of flame, filler material and method of moving torch
- The temperature generated during the process is 33000c.
- When the metal is fused, oxygen from the atmosphere and the torch combines with molten metal and forms oxides, results defective weld
- Fluxes are added to the welded metal to remove oxides
- Common fluxes used are made of sodium, potassium. Lithium and borax.
- Flux can be applied as paste, powder, liquid. solid coating or gas.

GAS WELDING EQUIPMENT

1. Gas Cylinders

Pressure

Oxygen – 125 kg/cm²

Acetylene – 16 kg/cm²

2. Regulators

Working pressure of oxygen 1 kg/cm²

Working pressure of acetylene 0.15 kg/cm²

Working pressure varies depends upon the thickness of the work pieces welded.

3. Pressure Gauges

4. Hoses

5. Welding torch

6. Check valve

7. Non return valve

Types of Flames

- Oxygen is turned on, flame immediately changes into a long white inner area (Feather) surrounded by a transparent blue envelope is called **Carburizing flame** (30000c)
- Addition of little more oxygen give a bright whitish cone surrounded by the transparent blue envelope is called **Neutral flame** (It has a balance of fuel gas and oxygen) (32000c)
- Used for welding steels, aluminium, copper and cast iron
- If more oxygen is added, the cone becomes darker and more pointed, while the envelope becomes shorter and more fierce is called **Oxidizing flame**
- Has the highest temperature about 34000c
- Used for welding brass and brazing operation

(a) Neutral flame

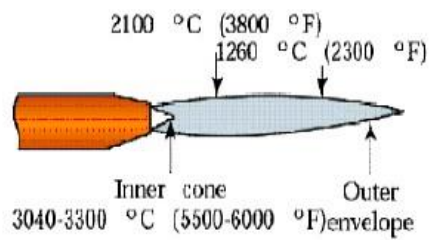

(b) Oxidizing flame

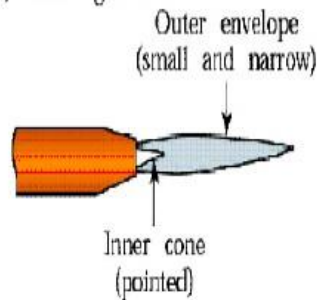

(c) Carburizing (reducing) flame

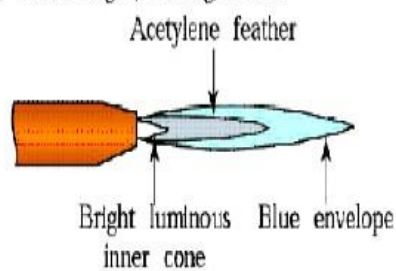

Three basic types of oxyacetylene flames used in oxyfuel-gas welding and cutting operations:

(a) neutral flame; (b) oxidizing flame; (c) carburizing, or reducing flame.

Fusion welding processes

- Definition : Fusion Welding is defined as melting together and coalescing materials by means of heat
- Energy is supplied by thermal or electrical means
- Fusion welds made without filler metals are known as autogenous welds

Filler Metals:

- Additional material to weld the weld zone
- Available as rod or wire
- They can be used bare or coated with flux
- The purpose of the flux is to retard the

Shielded metal arc welding process

- An electric arc is generated between a coated electrode and the parent metal
- The coated electrode carries the electric current to form the arc, produces a gas to control the atmosphere and provides filler metal for the weld bead
- Electric current may be AC or DC. If the current is DC, the polarity will affect the weld size and application

Process

- Intense heat at the arc melts the tip of the electrode
- Tiny drops of metal enter the arc stream and are deposited on the parent metal
- As molten metal is deposited, a slag forms over the bead which serves as an insulation against air contaminants during cooling
- After a weld 'pass' is allowed to cool, the oxide layer is removed by a chipping hammer and then cleaned with a wirebrush before the next pass.

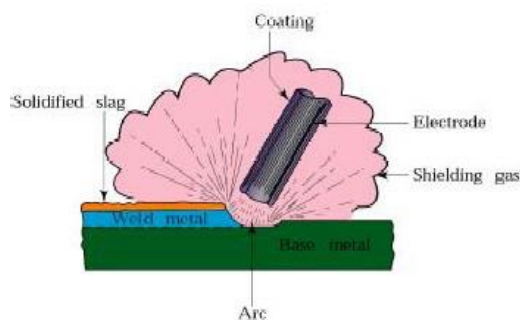

Fig : Schematic illustration of the shielded metal-arc welding process. About 50% of all large-scale industrial welding operations use this process.

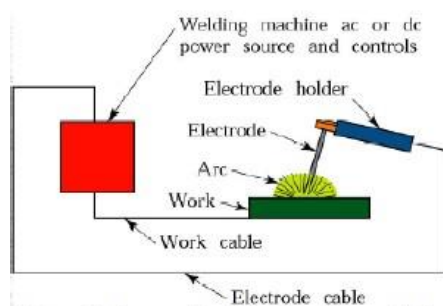

Fig : Schematic illustration of the shielded metal-arc welding process (also known as stick welding, because the electrode is in the shape of a stick).

Submerged arc welding

- Weld arc is shielded by a granular flux , consisting of silica, lime, manganese oxide, calcium fluoride and other compounds.
- Flux is fed into the weld zone by gravity flow through nozzle

- Thick layer of flux covers molten metal
- Flux acts as a thermal insulator ,promoting deep penetration of heat into the work piece
- Consumable electrode is a coil of bare round wire fed automatically through a tube
- Power is supplied by 3-phase or 2-phase power lines

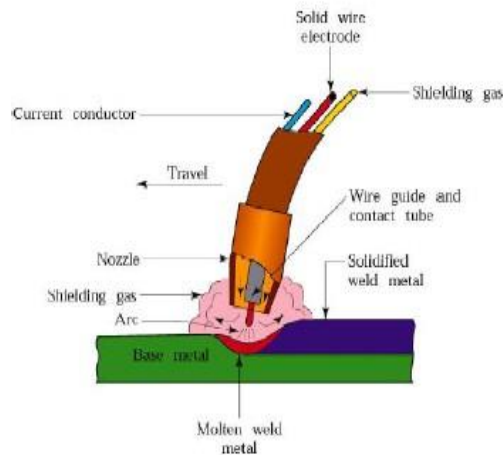

Fig : Schematic illustration of the submerged-arc welding process and equipment. The unfused flux is recovered and reused.

Gas metal arc welding

- GMAW is a metal inert gas welding (MIG)
- Weld area shielded by an effectively inert atmosphere of argon, helium, carbon dioxide, various other gas mixtures
- Metal can be transferred by 3 methods :
 - Spray transfer
 - Globular transfer
 - Short circuiting

Process capabilities

- GMAV process is suitable for welding a variety of ferrous and non-ferrous metals
- Process is versatile ,rapid, economical, welding productivity is double that of SMAW

Flux cored arc welding

- Flux cored arc welding is similar to a gas metal arc welding
- Electrode is tubular in shape and is filled with flux
- Cored electrodes produce more stable arc improve weld contour and produce better mechanical properties
- Flux is more flexible than others

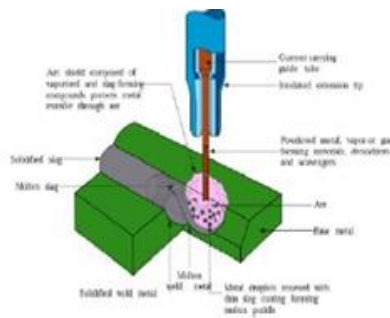

Fig : Schematic illustration of the flux-cored arc-welding process. This operation is similar to gas metal-arc welding.

Electro gas Welding

- EGW is welding the edges of sections vertically in one pass with the pieces placed edge to edge
- Similar to Electro gas welding
- Weld metal is deposited into weld cavity between the two pieces to be joined
- Difference is Arc is started between electrode tip and bottom part of the part to be welded
- Flux added first and then melted by the heat on the arc
- Molten slag reaches the tip of the electrode and the arc is extinguished
- Heat is then continuously produced by electrical resistance of the molten slag
- Single or multiple solid as well as flux-cored electrodes may be used

Process capabilities

- Weld thickness ranges from 12mm to 75mm
- Metals welded are steels, titanium, aluminum alloys
- Applications are construction of bridges, pressure vessels, thick walled and large diameter pipes, storage tanks and ships.

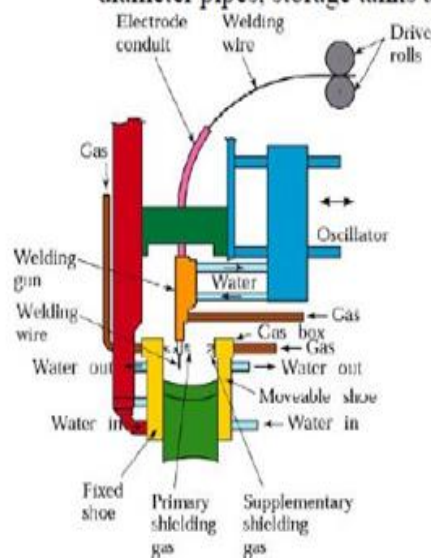

Fig : Schematic illustration of the electrogas welding process

Brazing:

It is a low temperature joining process. It is performed at temperatures above 840° F and it generally affords strengths comparable to those of the metal which it joins. It is low temperature in that it is done below the melting point of the base metal. It is achieved by diffusion without fusion (melting) of the base

Brazing can be classified as

- Torch brazing
- Dip brazing
- Furnace brazing
- Induction brazing

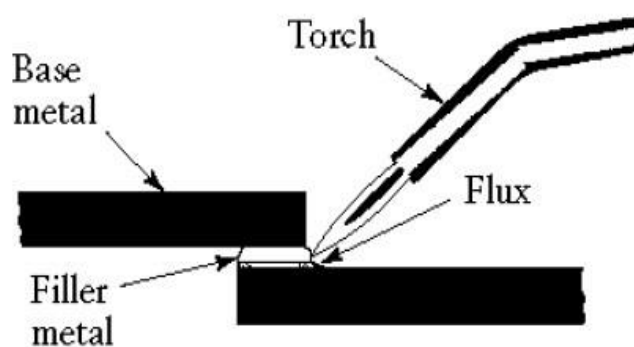

Advantages

- Dissimilar metals which cannot be welded can be joined by brazing
- Very thin metals can be joined
- Metals with different thickness can be joined easily
- In brazing thermal stresses are not produced in the work piece. Hence there is no distortion
- Using this process, carbides tips are brazed on the steel tool holders

Disadvantages

- Brazed joints have lesser strength compared to welding
- Joint preparation cost is more
- Can be used for thin sheet metal sections

Soldering

- It is a low temperature joining process. It is performed at temperatures below 840°F for joining.
- Soldering is used for,
 - Sealing, as in automotive radiators or tin cans
 - Electrical Connections
 - Joining thermally sensitive components
 - Joining dissimilar metals

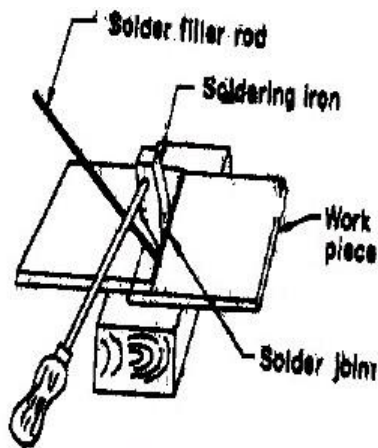

Inert Gas Welding

For materials such as Al or Ti which quickly form oxide layers, a method to place an inert atmosphere around the weld puddle had to be developed

Metal Inert Gas (MIG)

- Uses a consumable electrode (filler wire made of the base metal)
- Inert gas is typically Argon

Gas Tungsten Arc Welding (GTAW)

Uses a non-consumable tungsten electrode and an inert gas for arc shielding

- Melting point of tungsten = 3410°C (6170°F)
- A.k.a. Tungsten Inert Gas (TIG) welding
 - In Europe, called "WIG welding"
- Used with or without a filler metal
 - When filler metal used, it is added to weld pool from separate rod or wire
- Applications: aluminum and stainless steel most common

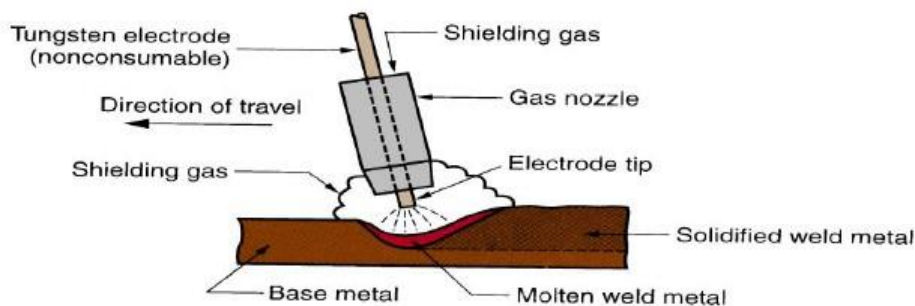

Advantages

- High quality welds for suitable applications
- No spatter because no filler metal through arc
- Little or no post-weld cleaning because no flux

Disadvantages

- Generally slower and more costly than consumable electrode AW processes

Plasma Arc Welding (PAW)

Special form of GTAW in which a constricted plasma arc is directed at weld area

- Tungsten electrode is contained in a nozzle that focuses a high velocity stream of inert gas (argon) into arc region to form a high velocity, intensely hot plasma arc stream
- Temperatures in PAW reach 28,000°C (50,000°F), due to constriction of arc, producing a plasma jet of small diameter and very high energy density

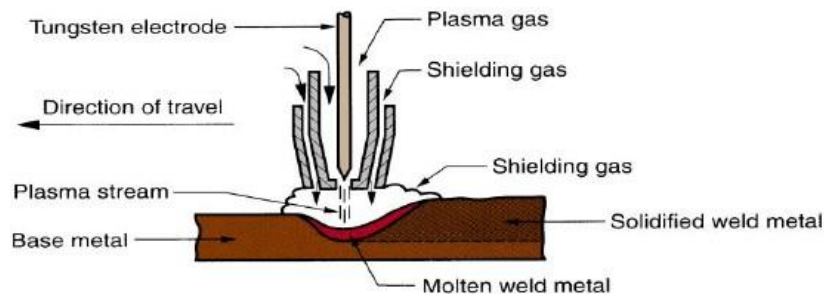

Resistance Welding (RW)

A group of fusion welding processes that use a combination of heat and pressure to accomplish coalescence

- Heat generated by electrical resistance to current flow at junction to be welded
- Principal RW process is resistance spot welding (RSW)

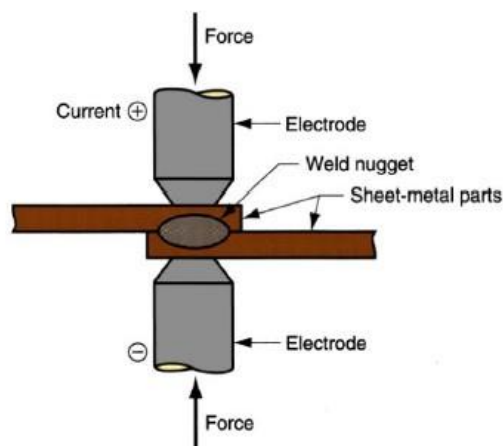

Fig: Resistance welding, showing the components in spot welding, the main process in the RW group.

Components in Resistance Spot Welding

- Parts to be welded (usually sheet metal)
- Two opposing electrodes
- Means of applying pressure to squeeze parts between electrodes
- Power supply from which a controlled current can be applied for a specified time duration

Advantages

- No filler metal required

- Tungsten electrode is contained in a nozzle that focuses a high velocity stream of inert gas (argon) into arc region to form a high velocity, intensely hot plasma arc stream
- Temperatures in PAW reach 28,000°C (50,000°F), due to constriction of arc, producing a plasma jet of small diameter and very high energy density

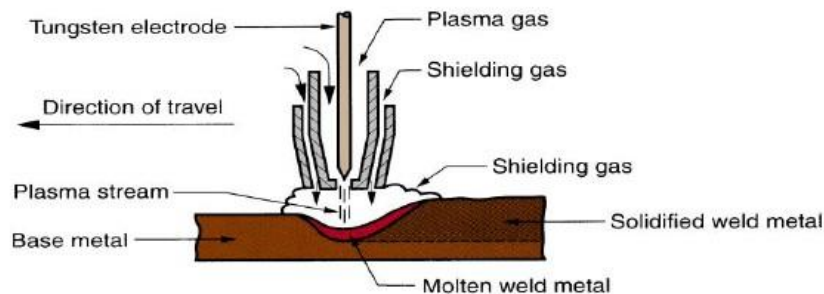

Resistance Welding (RW)

A group of fusion welding processes that use a combination of heat and pressure to accomplish coalescence

- Heat generated by electrical resistance to current flow at junction to be welded
- Principal RW process is resistance spot welding (RSW)

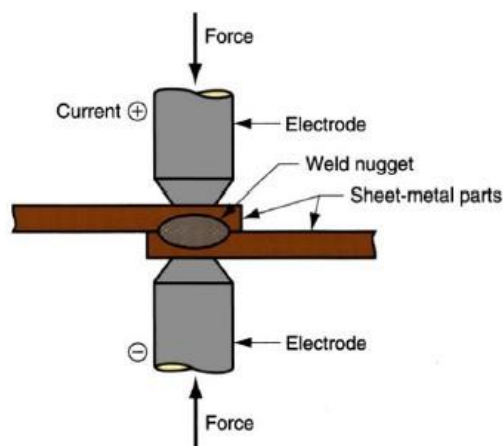

Fig: Resistance welding, showing the components in spot welding, the main process in the RW group.

Components in Resistance Spot Welding

- Parts to be welded (usually sheet metal)
- Two opposing electrodes
- Means of applying pressure to squeeze parts between electrodes
- Power supply from which a controlled current can be applied for a specified time duration

Advantages

- No filler metal required

- Filler metal not usually added
- High power density in small area, so LBW often used for small parts

Comparison: LBW vs. EBW

- No vacuum chamber required for LBW
- No x-rays emitted in LBW
- Laser beams can be focused and directed by optical lenses and mirrors
- LBW not capable of the deep welds and high depth-to-width ratios of EBW
 - Maximum LBW depth = ~ 19 mm (3/4 in), whereas EBW depths = 50 mm (2 in)

Thermit Welding (TW)

FW process in which heat for coalescence is produced by superheated molten metal from the chemical reaction of thermit

- Thermit = mixture of Al and Fe_3O_4 fine powders that produce an exothermic reaction when ignited
- Also used for incendiary bombs
- Filler metal obtained from liquid metal
- Process used for joining, but has more in common with casting than welding

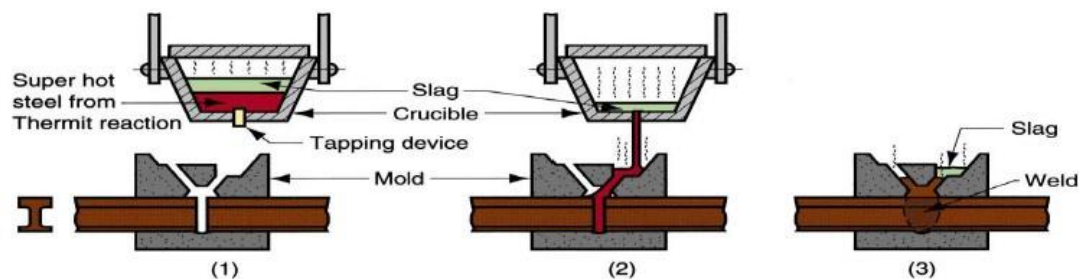

Fig: Thermit welding: (1) Thermit ignited; (2) crucible tapped, superheated metal flows into mold; (3) metal solidifies to produce weld joint.

Applications

- Joining of railroad rails
- Repair of cracks in large steel castings and forgings
- Weld surface is often smooth enough that no finishing is required

Diffusion Welding (DFW)

SSW process uses heat and pressure, usually in a controlled atmosphere, with sufficient time for diffusion and coalescence to occur

- Temperatures $\leq 0.5 T_m$
- Plastic deformation at surfaces is minimal
- Primary coalescence mechanism is solid state diffusion
- Limitation: time required for diffusion can range from seconds to hours

Applications

- Joining of high-strength and refractory metals in aerospace and nuclear industries
- Can be used to join either similar and dissimilar metals
- For joining dissimilar metals, a filler layer of different metal is often sandwiched between base metals to promote diffusion

Friction Welding (FRW)

SSW process in which coalescence is achieved by frictional heat combined with pressure

- When properly carried out, no melting occurs at faying surfaces
- No filler metal, flux, or shielding gases normally used
- Process yields a narrow HAZ
- Can be used to join dissimilar metals
- Widely used commercial process, amenable to automation and mass production

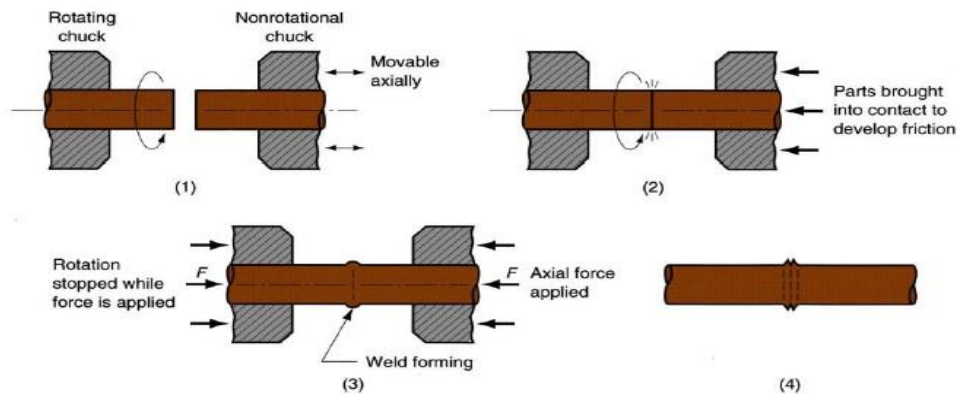

Fig: Friction welding (FRW): (1) rotating part, no contact; (2) parts brought into contact to generate friction heat; (3) rotation stopped and axial pressure applied; and (4) weld created.

Applications

- Shafts and tubular parts
- Industries: automotive, aircraft, farm equipment, petroleum and natural gas

Limitations

- At least one of the parts must be rotational
- Flash must usually be removed
- Upsetting reduces the part lengths (which must be taken into consideration in product design)

Weld Defects

- Undercuts/Overlaps
- Grain Growth

A wide ΔT will exist between base metal and HAZ. Preheating and cooling methods will affect the brittleness of the metal in this region

- Blowholes

Are cavities caused by gas entrapment during the solidification of the weld puddle. Prevented by proper weld technique (even temperature and speed)

- Inclusions

Impurities or foreign substances which are forced into the weld puddle during the welding process. Has the same effect as a crack. Prevented by proper technique/cleanliness.

- Segregation

Condition where some regions of the metal are enriched with an alloy ingredient and others aren't. Can be prevented by proper heat treatment and cooling.

- Porosity

The formation of tiny pinholes generated by atmospheric contamination.

Prevented by keeping a protective shield over the molten weld puddle.

MODULE-III

METAL FORMING

Cold working

The process is usually performed at room temperature, but mildly elevated temperatures may be used to provide increased ductility and reduced strength

For example: Deforming lead at room temperature is a hot working process because the recrystallization temperature of lead is about room temperature.

Effects of Cold Working

Deformation using cold working results in

- Higher stiffness, and strength, but
- Reduced malleability and ductility of the metal.
- Anisotropy

Advantages

- No heating is required
- Strength, fatigue and wear properties are improved through strain hardening
- Superior dimensional control is achieved, so little, if any, secondary machining is required
- Better surface finish is obtained
- Products possess better reproducibility and interchangeability
- Directional properties can be imparted
- Contamination problems are minimized

Disadvantages

- Higher forces are required to initiate and complete the deformation
- Less ductility is available
- Intermediate anneals may be required to compensate for the loss of ductility that accompanies strain hardening
- Heavier and more powerful equipment is required
- Metal surfaces must be clean and scale-free
- Imparted directional properties may be detrimental
- Undesirable residual stresses may be produced

Hot working

Hot working is the deformation that is carried out above the recrystallization temperature.

Effects of hot working

· At high temperature, scaling and oxidation exist. Scaling and oxidation produce undesirable surface finish. Most ferrous metals needs to be cold worked after hot working in order to improve the surface finish.

- The amount of force needed to perform hot working is less than that for cold work.
- The mechanical properties of the material remain unchanged during hot working.

· The metal usually experiences a decrease in yield strength when hot worked. Therefore, it is possible to hot work the metal without causing any fracture.

Quenching is the sudden immersion of a heated metal into cold water or oil. It is used to make the metal very hard. To reverse the effects of quenching, tempering is used (reheated of the metal for a period of time)

To reverse the process of quenching, tempering is used, which is the reheat of the metal.

Cold-working Processes

- Squeezing
- Bending
- Shearing
- Drawing
- Presses

Classifications of Squeezing Processes

- Rolling
- Cold Forging
- Sizing
- Staking
- Staking
- Coining
- Burnishing
- Extrusion
- Peening
- Hubbing

ROLLING

Process used in sheets, strips, bars, and rods to obtain products that have smooth surfaces and accurate dimensions; most cold-rolling is performed on four-high or cluster-type rolling mills



ROLLING PROCESS

Flat Rolling

A sheet or block or strip stock is introduced between rollers and then compressed and squeezed. Thickness is reduced. The amount of strain (deformation) introduced determines the hardness, strength and other material properties of the finished product.
Used to produce sheet metals predominantly

Swaging

Process that reduces/increases the diameter, tapers, rods or points round bars or tubes by external hammering

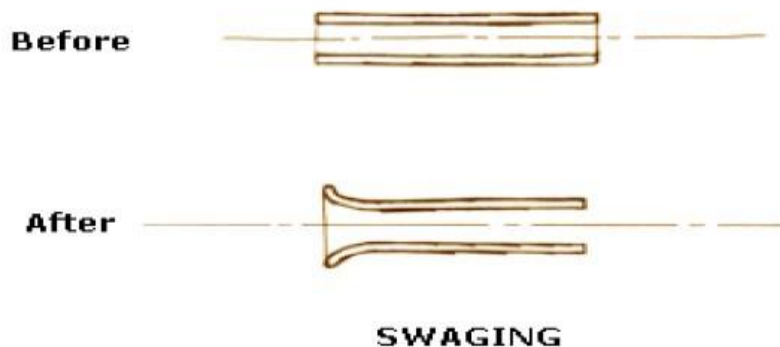

Cold Forging

Process in which slugs of material are squeezed into shaped die cavities to produce finished parts of precise shape and size.



COLD HEADING/COLD FORGING

Extrusion

Process which is commonly used to make collapsible tubes such as toothpaste tubes, cans usually using soft materials such as aluminum, lead, tin. Usually a small shot of solid material is placed in the die and is impacted by a ram, which causes cold flow in the material.



Sizing

Process of squeezing all or selected areas of forgings, ductile castings, or powder metallurgy products to achieve a desired thickness or precision

Riveting

Process where a head is formed on the shank end of a fastener to permanently join sheets or plates of material:

Staking

Process of permanently joining parts together when one part protrudes through a hole in the other; a shaped punch is driven into the end of the protruding piece where a deformation is formed causing a radial expansion, mechanically locking the two pieces together

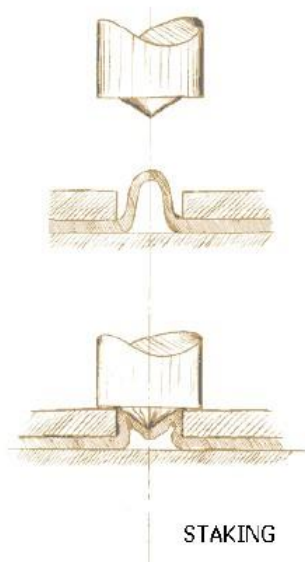

Coining

Process where metal while it is confined in a closed set of dies; used to produce coins, medals, and other products where exact size and fine details are required, and thickness varies about a well-defined average

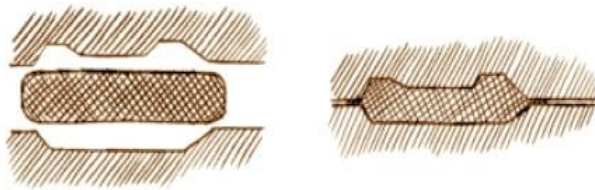

Before

After

COINING

Peening

Process where the surface of the metal is blasted by shot pellets; the mechanical working of surfaces by repeated blows of impelled shot or a round-nose tool

Burnishing

Process by which a smooth hard tools is rubbed on the metal surface and flattens the high spots by applying compressive force and plastically flowing the material

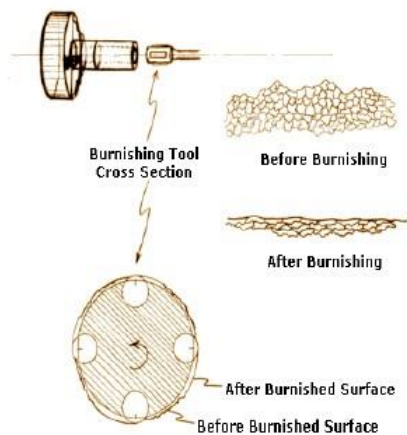

BURNISHING

Hubbing

Process is used to form recessed cavities in various types of female tooling dies. This is often used to make plastic extrusion dies in an economical manner

Thread Rolling

Process is used for making external threads; in this process, a die, which is a hardened tool with the thread profile, is pressed on to a rotating workpiece



THREAD ROLLING

The Presses

There are many kinds of machines

- Hydraulic presses
- Mechanical presses
 - C frame
 - Straight sided
- Others

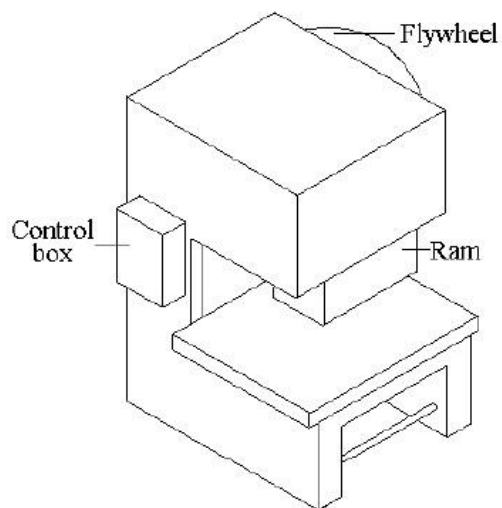

C-frame mechanical press

MODULE-IV

EXTRUSION AND RAPID PROTOTYPING

Extrusion

Process by which long straight metal parts can be produced.

Cross-sections that can be produced vary from solid round, rectangular, to L shapes, T Shapes, tubes and many other different types

Done by squeezing metal in a closed cavity through a die using either a mechanical or hydraulic press.

Extrusion produces compressive and shear forces in the stock.

No tension is produced, which makes high deformation possible without tearing the metal.

Can be done Hot or cold

Drawing

Section of material reduced by pulling through die.

Similar to extrusion except material is under TENSILE force since it is pulled through the die

Various types of sections: - round, square, profiles

Tube Drawing

Utilizes a special tool called a MANDREL is inserted in a tube hollow section to draw a seamless tube

- Mandrel and die reduce both the tube's outside diameter and its wall thickness. The mandrel also makes the tube's inside surface smoother

Process Variations. Slab forging, shaft forging, mandrel forging, ring forging, upsetting between flat or curved dies, drawing out.

Application. Forging ingots, large and bulky forgings, preforms for finished forgings.

Closed Die Forging

In this process, a billet is formed (hot) in dies (usually with two halves) such that the flow of metal from the die cavity is restricted. The excess material is extruded through a restrictive narrow gap and appears as flash around the forging at the die parting line.

Equipment. Anvil and counterblow hammers, hydraulic, mechanical, and screw presses.

Materials. Carbon and alloy steels, aluminum alloys, copper alloys, magnesium alloys, beryllium, stainless steels, nickel alloys, titanium and titanium alloys, iron and nickel and cobalt super alloys.

Process Variations. Closed-die forging with lateral flash, closed-die forging with longitudinal flash, closed-die forging without flash.

Application. Production of forgings for automobiles, trucks, tractors, off-highway equipment, aircraft, railroad and mining equipment, general mechanical industry, and energy-related engineering production.

Forward extrusion

Forward extrusion reduces slug diameter and increases its length to produce parts such as stepped shafts and cylinders.

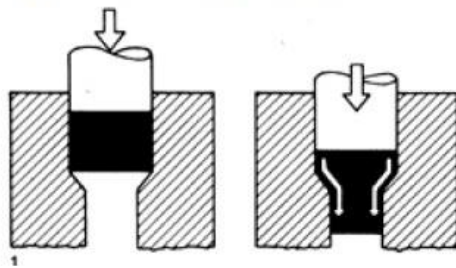

backward extrusion

In backward extrusion, the steel flows back and around the descending punch to form cup-shaped pieces.

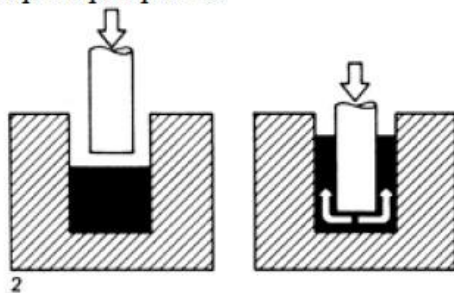

Upsetting, or heading

Upsetting, or heading, a common technique for making fasteners, gathers steel in the head and other sections along the length of the part.

Extrusion is a process in which the metal is subjected to plastic flow by enclosing the metal in a closed chamber in which the only opening provided is through a die. The material is usually treated so that it can undergo plastic deformation at a sufficiently rapid rate and may be squeezed out of the hole in the die. In the process the metal assumes the opening provided in the die and comes out as a long strip with the same cross-section as the die-opening. Incidentally, the metal strip produced will have a longitudinal grain flow. The process of extrusion is most commonly used for the manufacture of solid and hollow sections of nonferrous metals and alloys e.g., aluminium, aluminium-magnesium alloys, magnesium and its alloys, copper, brass and bronze etc. However, some steel products are also made by extrusion.

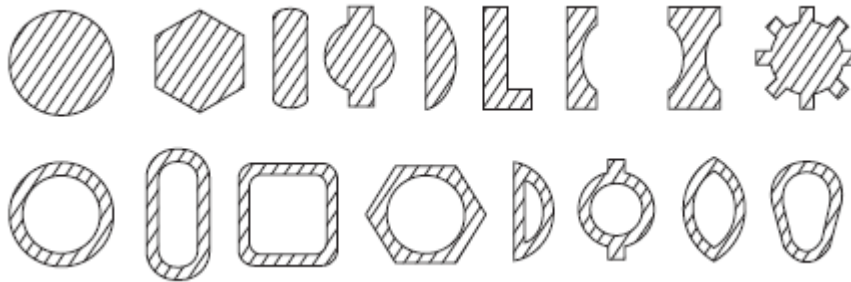

The stock or the material to be extruded is in the shape of cast ingots or billets. Extrusion may be done hot or cold. The cross-sections of extruded products vary widely. Some of these sections are shown in Figure above

EXTRUSION PROCESSES

Extrusion processes can be classified as followed:

(A) Hot Extrusion

- (i) Forward or Direct extrusion.
- (ii) Backward or Indirect extrusion.

(B) Cold Extrusion

- (i) Hooker extrusion.
- (ii) Hydrostatic extrusion.
- (iii) Impact extrusion.
- (iv) Cold extrusion forging.

Forward or direct extrusion process: In this process, the material to be extruded is in the form of a block. It is heated to requisite temperature and then it is transferred inside a chamber as shown in Figure. In the front portion of the chamber, a die with an opening in the shape of the cross-section of the extruded product, is fitted. The block of material is pressed from behind by means of a ram and a follower pad. Since the chamber is closed on all sides, the heated material is forced to squeeze through the die-opening in the form of a long strip of the required cross-section.

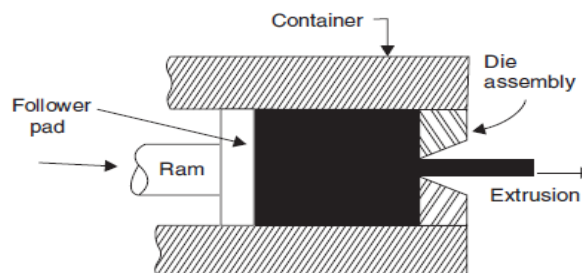

Backward or indirect extrusion: This process is depicted in Figure As shown; the block of heated metal is inserted into the container/chamber. It is confined on all sides by the container wall except in front; where a ram with the die presses upon the material. As the ram presses backwards, the material has to flow forwards through the opening in the die. The ram is made hollow so that the bar of extruded metal may pass through it unhindered.

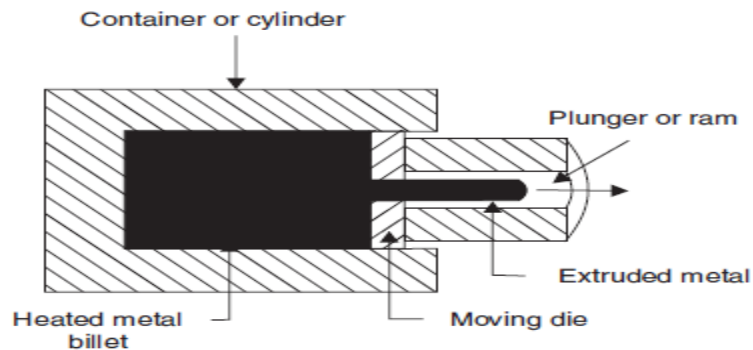

This process is called backward extrusion process as the flow of material is in a direction opposite to the movement of the ram. In the forward extrusion process the flow of material and ram movement were both in the same direction. The following table compares the forwards (direct) and backwards (Indirect extrusion process).

Hooker extrusion process: This process is also known as extrusion down method. It is used for producing small thin walled seamless tubes of aluminium and copper. This is done in two stages. In the first stage the blank is converted into a cup shaped piece. In the second stage, the walls of the cup are thinned and it is elongated. The process can be understood by referring to Figure. This process is a direct extrusion process.

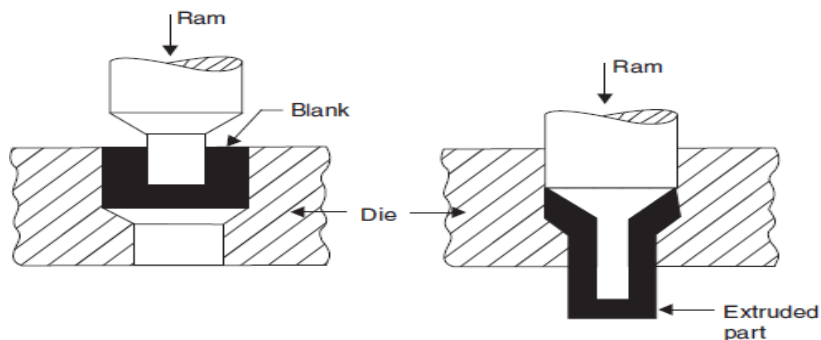

Hydrostatic extrusion: This is a direct extrusion process. But the pressure is applied to the metal blank on all sides through a fluid medium. The fluids commonly used are glycerine, ethyl glycol, mineral oils, castor oil mixed with alcohol etc. Very high pressures are used – 1000 to 3000 MPa. Relatively brittle materials can also be successfully extruded by this method.

Impact extrusion: In this process, which is shown in Figure below the punch descends with high velocity and strikes in the centre of the blank which is placed in a die. The material deforms and fills up the annular space between the die and the punch flowing upwards. Before the use of laminated plastic for manufacturing tooth paste, shaving cream tubes etc., these collapsible tubes containing paste were and are still made by this process. This process is actually a backward extrusion process.

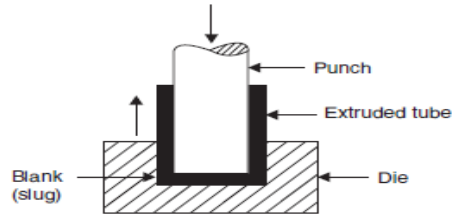

Cold extrusion forging: This process is depicted in Figure below. This is generally similar to the impact extrusion process; but there are two differences: 1. In this process the punch descends slowly, and 2. The height of extruded product is short and the side walls are much thicker than the thin-walled products produced by the impact extrusion process. In essence, this process is one of backward extrusion.

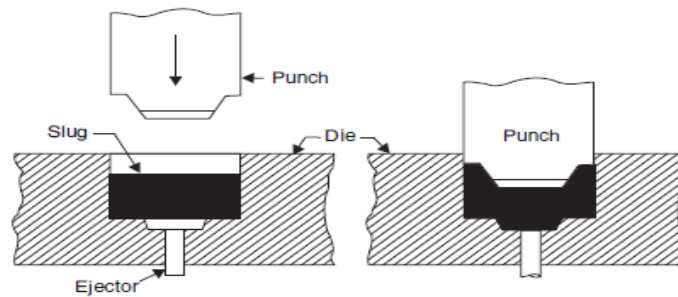

MACHINES FOR EXTRUSION

Both hydraulic and mechanical presses of horizontal and vertical configuration are used for extrusion. They should be capable of exerting high forces and their rams should have long strokes. To reduce friction between metal and extrusion chamber walls, lubricants are used. The dies and punches are made from good quality alloy steels which are known as hot and cold die steels. Extrusion speed is of the order of 0.5 m/sec for light alloys and 4.5 m/sec for copper alloys.

EXTRUSION DEFECTS

Sometimes the surface of extruded metal/products develop surface cracks. This is due to heat generated in the extrusion process. These cracks are specially associated with aluminium, magnesium and zinc alloy extrusions. The extruded product can develop internal cracks also. These are variously known as centre burst, centre cracking and arrowhead fracture. The tendency for centre cracking increases with increasing die angles and material impurities.

WIRE DRAWING

Wire drawing is a simple process. In this process, rods made of steel or non ferrous metals and alloys are pulled through conical dies having a hole in the centre. The included angle of the cone is kept between 8 to 24°. As the material is pulled through the cone, it undergoes plastic deformation and it gradually undergoes a reduction in its diameter. At the same time, the length is increased proportionately.

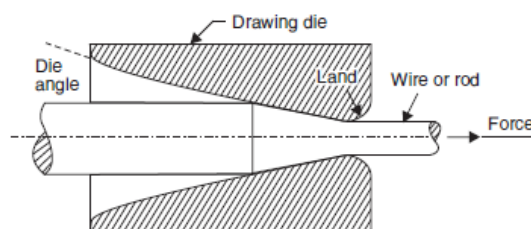

The dies tend to wear out fast due to continuous rubbing of metal being pulled through it. Hence they are made of very hard material like alloy steel, tungsten carbide or even diamond. In one pass, the reduction in cross-sectional area achieved is about 25–30%. Hence in a wire drawing plant, the wire has to pass through a number of dies of progressively reducing diameter to achieve the required reduction in diameter. However as the wire passes through dies and undergoes plastic deformation, it gets strain hardened. Its strength increases and capacity to further undergo plastic deformation decreases. Therefore during the entire run of the wire, from time to time, it has to be heated (and cooled) to remove the effect of work-hardening. This process is called “in process annealing”. The aim is to make the material soft and ductile again so that the process of drawing may be smoothly carried out. The metal rods to be drawn into wires must be absolutely clean. If necessary, they are pickled in an acid bath to dissolve the oxide layer present on the surface. Its front end is then tapered down so that it may pass through the hole in the die which is firmly held in the wire drawing machine. The wire is drawn by means of a number of power driven spools or rotating drums.

During wire drawing, a great deal of heat is generated due to friction between the wire rod and the die. To reduce friction, dry soap or a synthetic lubricant is used. But despite reducing friction, the dies and drums may have to be water cooled. The preferred material for dies is tungsten carbide but for drawing fine wire, use of ruby or diamond dies is preferred.

The drawing machines can be arranged in tandem so that the wire drawn by the previous die may be collected (in coil form) in sufficient quantity before being fed into the next die for further reduction in diameter. As the diameter becomes smaller, the linear speed of wire drawing is increased.

The major variables in wire drawing process are (1) Reduction ratio (2) Die angle and (3) Friction. Improper control of these parameters will cause defects in the drawn material. Defects include centre cracking (as in extrusion and for the same reasons) and formation of longitudinal scratches or folds in the material.

TUBE DRAWING

The ‘drawing’ process can also be used for tube drawing. Tube drawing does not mean manufacturing a tube from solid raw material. It means lengthening a tube reducing its diameter. Various arrangements used for tube drawing as shown in figure below

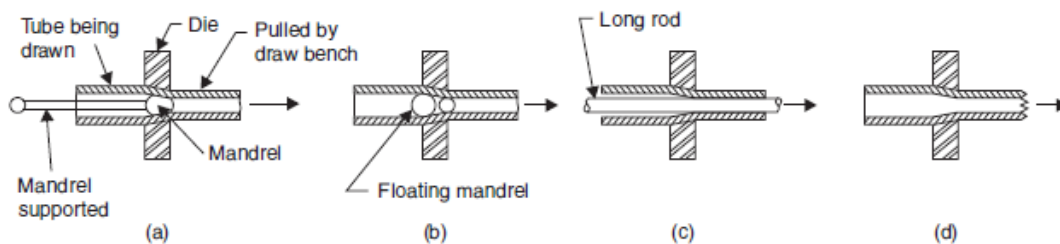

- Method (a) is most commonly used.
- Method (b) uses a floating mandrel which adjusts itself to the correct position because of its stepped contour.

The method shown in Fig. (a) is the most common method used for tube drawing. A conventional tube drawing bench is used. Method shown in Fig. (b) Employs a floating mandrel. Method shown in Fig. (c) uses a long circular rod to control the size of tube-bore. Method shown in Fig. (d) uses neither a mandrel nor a bar and controlling size of bore is difficult.

TUBE MAKING

Tubes and pipes are required in large quantities by industries all over the world. Tubes are basically of two types. They are either seamless (*i.e.*, without any joint) or with joint all along the length of the tube. Seamless tubes are made by processes such as casting, extrusion or rolling. Tubes with joint are made by welding. Usually, the weld joint is made by electric resistance welding process, such tubes are referred to as ERW tubes. The size of a tube or pipe is indicated by the size of its bore in mm. Since the requirement of tubes is so large, a special rolling process called Mannesmann rotary piercing process has been developed. In this process, a heated round billet with its leading end, in the centre of which a short guide hole has been punched or drilled, is pushed longitudinally between two large tapered rolls as shown in Figure below

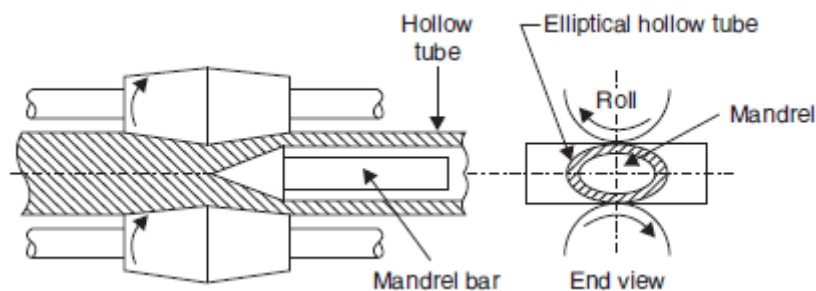

The rolls revolve in the same direction and their axes are inclined at opposite angles of approx 6° from the axis of the billet. As the billet is caught by the rolls and is rotated, their inclination causes the material to be drawn forward. The small clearance between the rolls forces the material to deform into an elliptical shape. Due to compressive forces, secondary tensile stresses start acting in a direction perpendicular to the direction of the compressive stresses. The guide hole drilled/punched at centre of billet tears open. This action is assisted by a suitably placed mandrel.

As the billet moves forward and keeps rotating the tearing action is propagated throughout the length of the billet. End result is a roughly formed seamless tube of elliptical cross-section. This roughly formed seamless tube is further rolled in a "plug rolling mill". The final operations of "reeling" and "sizing" are further conducted on cooled tube to improve size and finish of tubes.

Rapid prototyping

Though the principle of concurrent engineering (CE) is quite clear and the advantages of the concept for improved quality and reduced cost are implicit, it is not possible to incorporate CE effectively in the absence of some technique for quick development of prototype. To reduce the development time and adopt concurrent engineering in its true spirit, quick and inexpensive fabrication of prototype parts is essential and rapid prototyping technology has made that possible. A family of unique fabrication processes developed to make engineering prototypes in minimum lead time based on a CAD model of the item. The traditional method is machining –Machining can require significant lead-times –several weeks, depending on part complexity and difficulty in ordering materials •RP allows a part to be made in hours or days given that a computer model of the part has been generated on a CAD system.

Why Rapid Prototyping? Because product designers would like to have a physical model of a new part or product design rather than just a computer model or line drawing –Creating a prototype is an integral step in design –A virtual prototype (a computer model of the part design on a CAD system) may not be sufficient for the designer to visualize the part adequately –Using RP to make the prototype, the designer can visually examine and physically feel the part and assess its merits and shortcomings.

Basic principles of RP

In this process a solid object with prescribed shape, dimension and finish can be directly produced from the CAD based geometric model data stored in a computer without human intervention. Conventional method for producing parts like casting, forming, machining etc are not suitable for this purpose and a host of new processes for shaping objects directly from the CAD data have been developed and machines are in the market. Rapid prototyping can be of two types: – The parts obtained by RP technology can form the prototype directly without requiring any further processing. The parts obtained by RP technology can be used to make moulds for casting the prototype component. This type is needed because till today, the commercially available RP machines are non metallic materials with low strength and low melting temperature. In general this technology is called as Generative manufacturing Process (GMP) as the shape of the work piece is not obtained by removal of chips or forming or casting. It is achieved by addition of material without any prior recognizable form or shape and no tool is necessary.

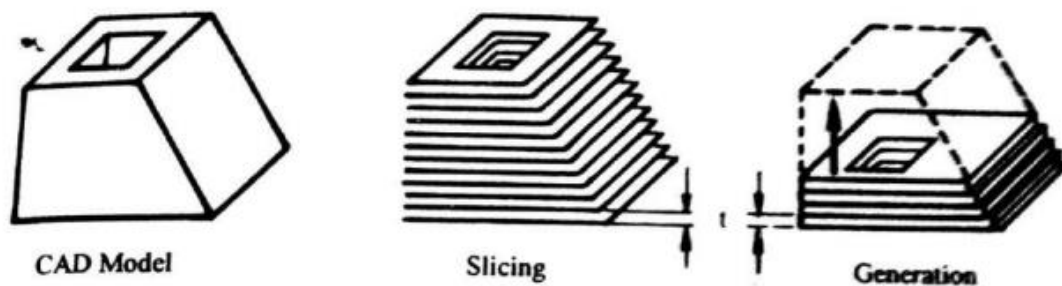

The slice thickness and slicing direction can be varied for convenience of generation. To generate an object of same shape as that of sliced CAD model, the distance between the slicing planes (t) must be equal to the thickness of the corresponding layers during the actual generation process.

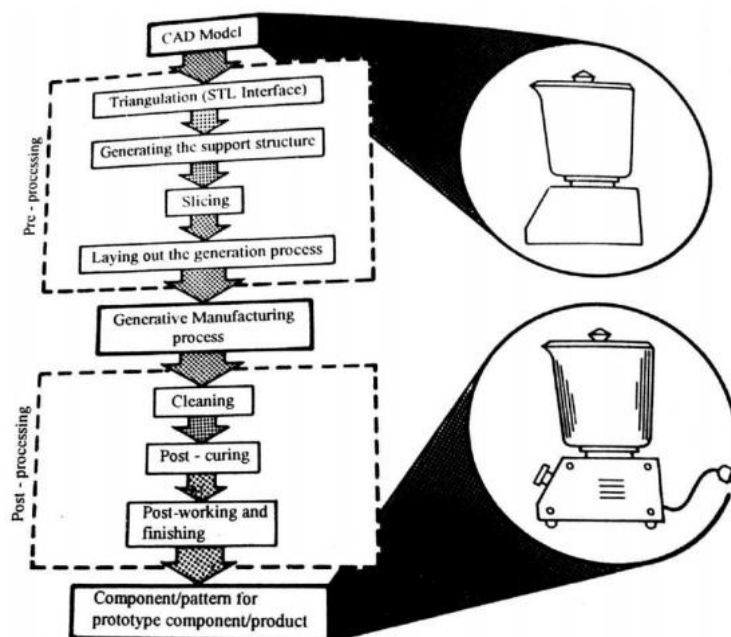

Steps involved in rapid prototyping

MODULE-V FORGING

Forging operations

Forging is a process in which the workpiece is shaped by compressive forces applied through various dies and tools. It is one of the oldest metalworking operations. Most forgings require a set of dies and a press or a forging hammer.

A Forged metal can result in the following: -

- Decrease in height, increase in section - open die forging
- Increase length, decrease cross-section, called drawing out.
- Decrease length, increase in cross-section on a portion of the length - upsetting
- Change length, change cross-section, by squeezing in closed impression dies - closed die forging. This results in favorable grain flow for strong parts

Types of forging

- Closed/impression die forging
- Electro-upsetting
- Forward extrusion
- Backward extrusion
- Radial forging
- Hobbing
- Isothermal forging
- Open-die forgig
- Upsetting
- Nosing
- Coining

Commonly used materials include

- Ferrous materials: low carbon steels
- Nonferrous materials: copper, aluminum and their alloys

Open-Die Forging

Open-die forging is a hot forging process in which metal is shaped by hammering or pressing between flat or simple contoured dies.

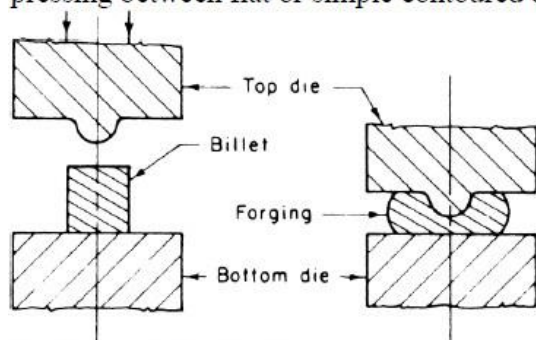

Equipment. Hydraulic presses, hammers.

Materials. Carbon and alloy steels, aluminum alloys, copper alloys, titanium alloys, all forgeable materials.

Process Variations. Slab forging, shaft forging, mandrel forging, ring forging, upsetting between flat or curved dies, drawing out.

Application. Forging ingots, large and bulky forgings, preforms for finished forgings.

Closed Die Forging

In this process, a billet is formed (hot) in dies (usually with two halves) such that the flow of metal from the die cavity is restricted. The excess material is extruded through a restrictive narrow gap and appears as flash around the forging at the die parting line.

Equipment. Anvil and counterblow hammers, hydraulic, mechanical, and screw presses.

Materials. Carbon and alloy steels, aluminum alloys, copper alloys, magnesium alloys, beryllium, stainless steels, nickel alloys, titanium and titanium alloys, iron and nickel and cobalt super alloys.

Process Variations. Closed-die forging with lateral flash, closed-die forging with longitudinal flash, closed-die forging without flash.

Application. Production of forgings for automobiles, trucks, tractors, off-highway equipment, aircraft, railroad and mining equipment, general mechanical industry, and energy-related engineering production.

Forward extrusion

Forward extrusion reduces slug diameter and increases its length to produce parts such as stepped shafts and cylinders.

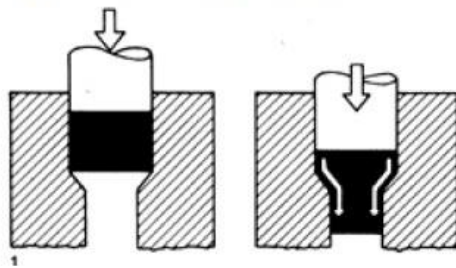

backward extrusion

In backward extrusion, the steel flows back and around the descending punch to form cup-shaped pieces.

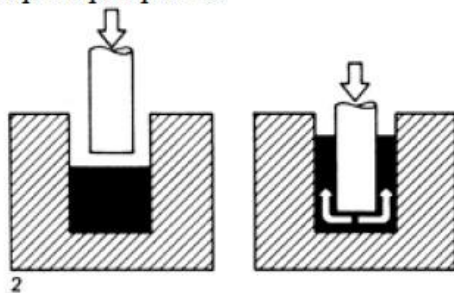

Upsetting, or heading

Upsetting, or heading, a common technique for making fasteners, gathers steel in the head and other sections along the length of the part.

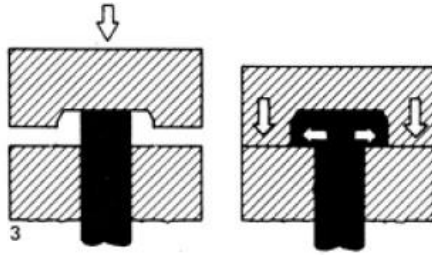

Electro-Upsetting (Fig. 2.4)

Electro-upsetting is the hot forging process of gathering a large amount of material at one end of a round bar by heating the bar end electrically and pushing it against a flat anvil or shaped die cavity.

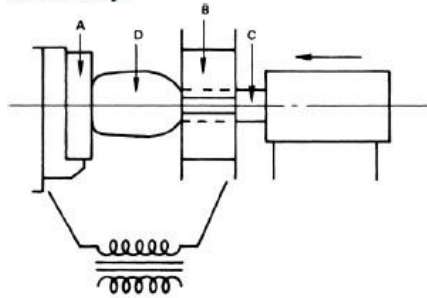

A, anvil electrode; B, gripping electrode; C, workpiece; D, upset end of workpiece

Equipment. Electric upsetters.

Materials. Carbon and alloy steels, titanium.

Application. Preforms for finished forgings.

Hobbing

Hobbing is the process of indenting or coining an impression into a cold or hot die block by pressing with a punch.

Equipment. Hydraulic presses, hammers.

Materials. Carbon and alloy steels.

Process Variations. Die hobbing, die typing.

Application. Manufacture of dies and molds with relatively shallow impressions.

Nosing

Nosing is a hot or cold forging process in which the open end of a shell or tubular component is closed by axial pressing with a shaped die.

Equipment. Mechanical and hydraulic presses, hammers.

Materials. Carbon and alloy steels, aluminum alloys, titanium alloys.

Process Variations. Tube sinking, tube expanding.

Applications. Forging of open ends of ammunition shells; forging of gas pressure containers.

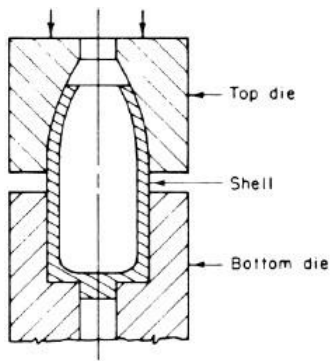

Coining

In sheet metal working, coining is used to form indentations and raised sections in the part. During the process, metal is intentionally thinned or thickened to achieve the required indentations or raised sections. It is widely used for lettering on sheet metal or components such as coins. Bottoming is a type of coining process where bottoming pressure causes reduction in thickness at the bending area.

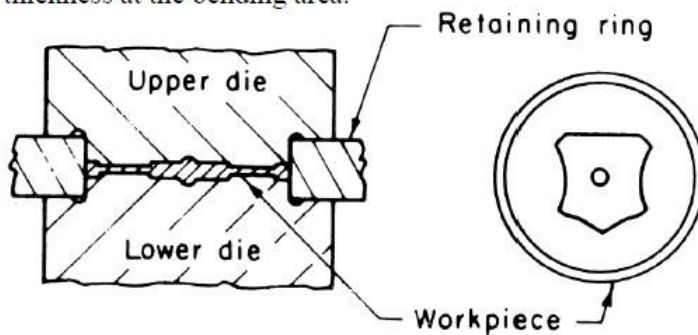

Ironing

Ironing is the process of smoothing and thinning the wall of a shell or cup (cold or hot) by forcing the shell through a die with a punch.

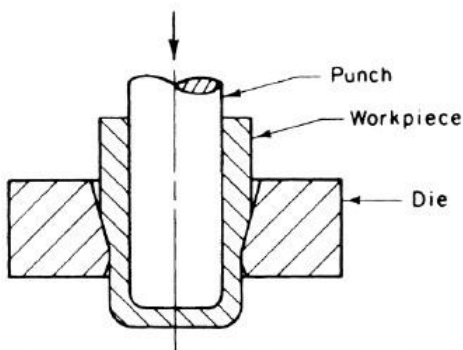

Equipment. Mechanical presses and hydraulic presses.

Materials. Carbon and alloy steels, aluminum and aluminum alloys, titanium alloys.

Applications. Shells and cups for various